

Squat

Assembly Instructions



LifeFitness

Squat

Assembly Instructions

Item	Qty	Description	Part Number
1	1	Platform Frame	80201XX
2	1	Tower	79854XX
3	4	M10 x 130mm Bolt	3251720
4	46	3/8" Flat Washer	3102514
5	15	M10 Nylock Nut	3242002
6	1	Center Brace	80202XX
7	4	M10 x 90mm Bolt	3251715
8	1	Upright	80203XX
9	11	M10 x 25mm Bolt	3251702
10	1	Upper Brace	80319XX
11	2	M10 x 70mm Bolt	3251711
12	1	Pivot Shaft	7316508
13	1	Long Spacer	7330007
14	2	Bearing	3235601
15	2	Short Spacer	7330001
16	1	Workarm	80204XX
17	1	Output Cam	7998501
18	1	Output Plate	7998495
19	1	Output Ring	7998895
20	6	M10 x 45mm Bolt	3251706

Item	Qty	Description	Part Number
21	1	Rear Shroud	8024808
22	1	Front Shroud	8024708
23	4	M10 x 20mm Bolt	3251701
24	1	Plate	7322301
25	1	Cam Guard	8013201
26	2	M5 x 10mm Phillips Screw	7511503
27	1	M10 Hex Jam Nut	3236901
28	1	Cable	8020601
29	1	Rod End Bearing	3237901
30	1	M10 x 40mm Bolt	3251705
31	1	Spacer	7489402
32	1	Cable Retaining Plate	8001801
33	2	M8 Hex Jam Nut	3247502
34	1	Output Cam Cover Plate	7998995
35	1	Platform	8018200
36	3	Leveling Shim	7893101
37	3	7/16" Hole Plug	3237401
38	6	1" Hole Plug	3237403
39	1	Multi-language Label	8047101

Tools Required:

- 17mm Wrench
- Metric Allen Wrench Set
- Ratchet with 17mm Socket
- Rubber Mallet
- Ratchet Extension
- Phillips Screwdriver

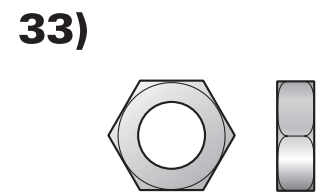
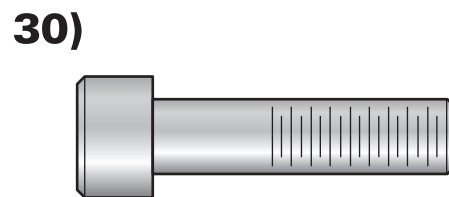
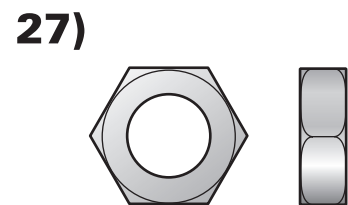
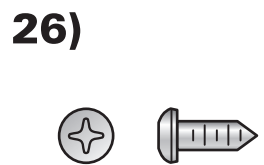
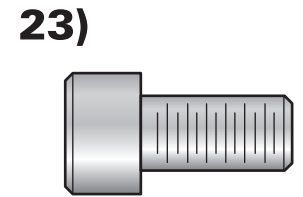
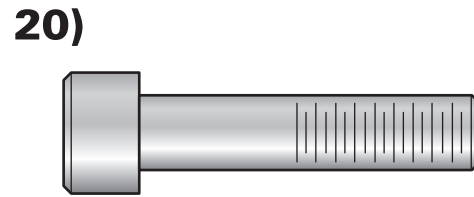
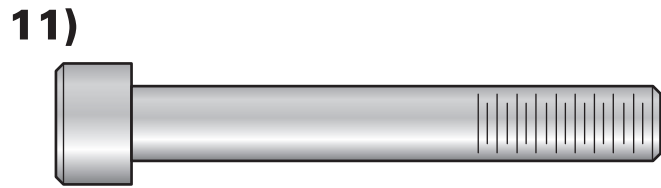
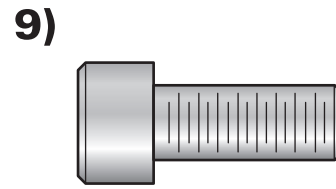
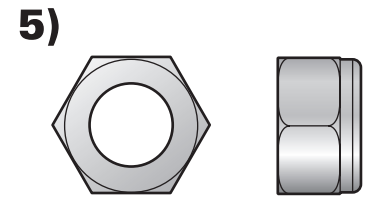
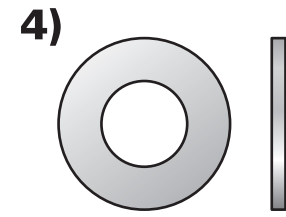
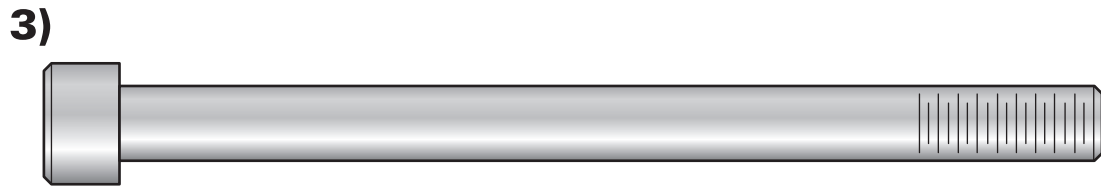

Squat

Assembly Instructions

1. LOOSELY assemble the PLATFORM FRAME (1) to the TOWER (2) using four M10 X 130mm BOLTS (3), eight 3/8" SAE WASHERS (4) and four M10 NYLOCK NUTS (5) as shown.
2. LOOSELY assemble the CENTER BRACE (6) to the PLATFORM FRAME (1) using two M10 X 90mm BOLTS (7), four 3/8" SAE WASHERS (4) and two M10 NYLOCK NUTS (5) as shown.
3. LOOSELY assemble the UPRIGHT (8) to the CENTER BRACE (6) using two M10 X 25mm BOLTS (9), two M10 X 90mm BOLTS (7), eight 3/8" SAE WASHERS (4) and four M10 NYLOCK NUTS (5)
LOOSELY assemble the UPPER BRACE (10) to the UPRIGHT (8) and TOWER (2) using two M10 X 25mm BOLTS (9), four 3/8" SAE WASHERS (4) and two M10 NYLOCK NUTS (5) at the UPRIGHT and two M10 X 70mm BOLTS (11), four 3/8" SAE WASHERS (4) and two M10 NYLOCK NUTS (5) at the TOWER as shown.
4. Tighten all BOLTS and NUTS securely.
5. Install the PIVOT SHAFT (12), LONG SPACER (13), two BEARINGS (14) and two SHORT SPACERS (15) into the PIVOT HOUSING (A) of the WORKARM (16).
6. Assemble the WORKARM (16) to the UPRIGHT (8) using two M10 X 25mm BOLTS (9) and two 3/8" SAE WASHERS (4) as shown. Tighten the BOLTS securely.

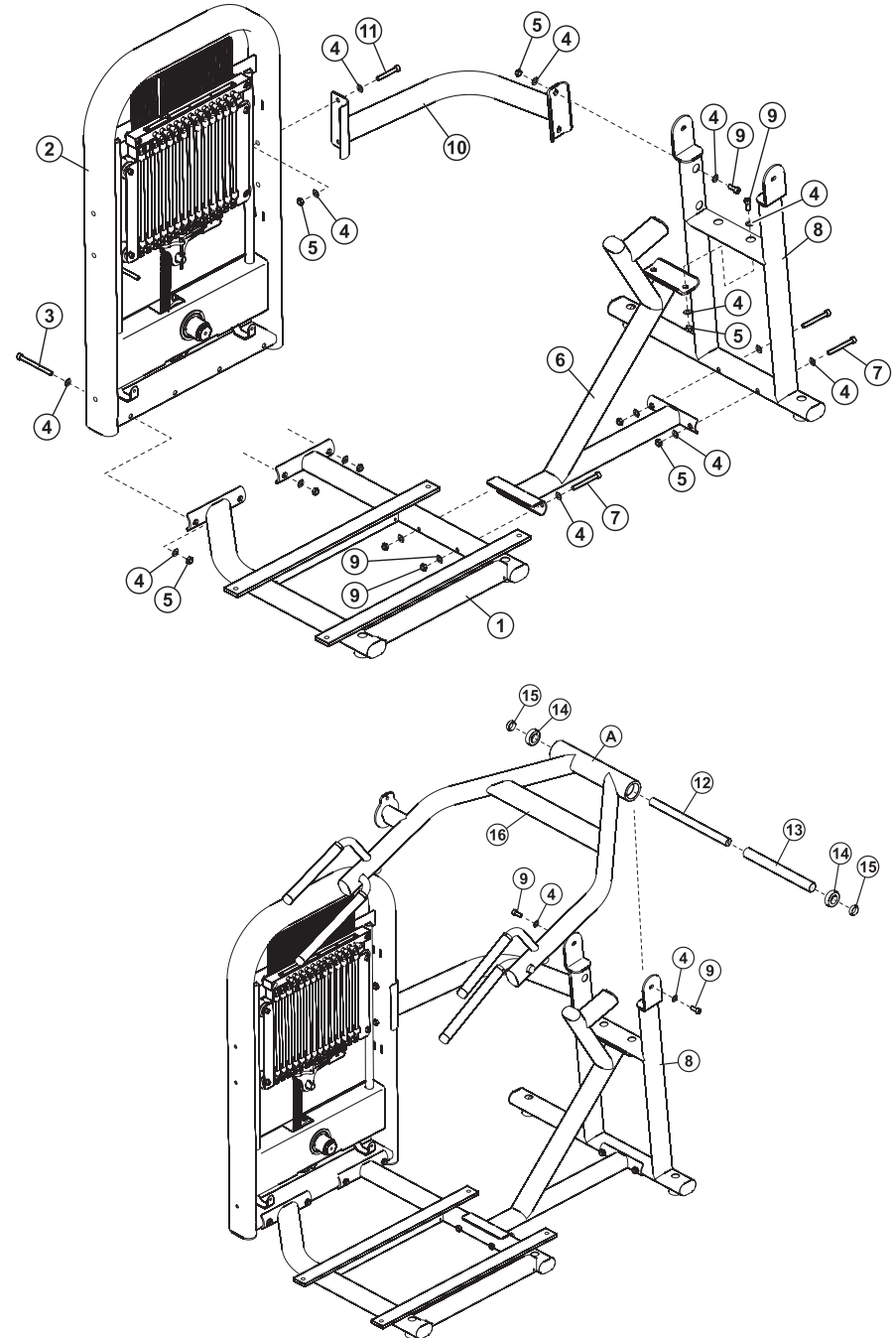

7. Assemble the OUTPUT CAM (17), OUTPUT PLATE (18), and OUTPUT RING (19) using three M10 X 45mm BOLTS (20) and three 3/8" SAE WASHERS (4) as shown. Tighten the BOLTS securely.

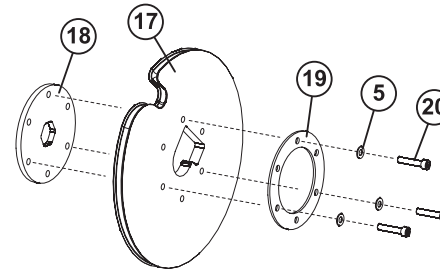

8. Assemble the REAR SHROUD (21) and FRONT SHROUD (22) to the TOWER (2) using four M10 X 20mm BOLTS (23), four 3/8" SAE WASHERS (4) as shown. Be sure all tabs along the sides and top of the SHROUDS are fully engaged in the slots located inside the TOWER. Tighten the BOLTS securely. Do not overtighten the BOLTS.
9. Secure the OUTPUT CAM ASSEMBLY (B) to the TOWER HUB (C) using one M10 X 25mm BOLTS (9), one 3/8" SAE WASHERS (4) and one PLATE (24) as shown. Tighten the BOLT securely.

IMPORTANT: Be sure the OUTPUT CAM ASSEMBLY is oriented as shown before securing it to the TOWER HUB.

10. Attach the CAM GUARD (25) to the FRONT SHROUD (22) using two M5 X 10mm PHILLIPS SCREWS (26). Tighten the SCREWS securely. Do not overtighten the SCREWS.

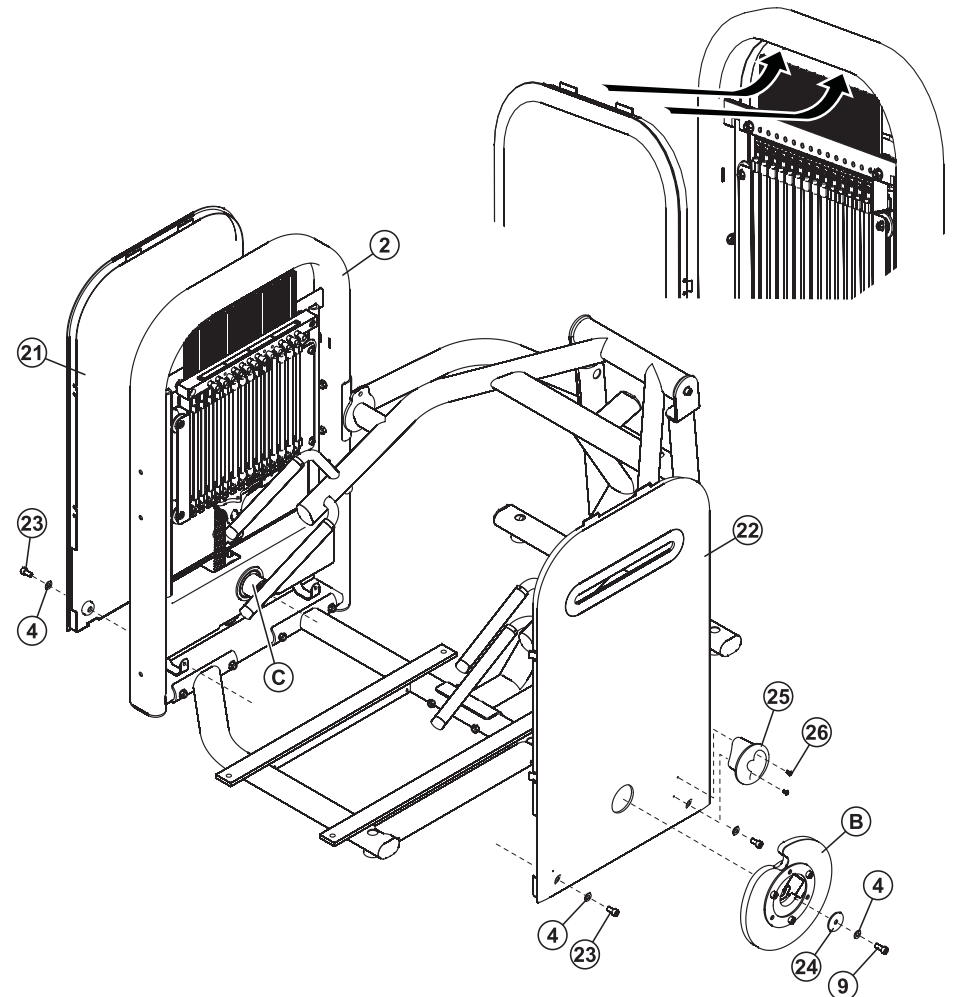

Squat

Assembly Instructions

NOTE: Some components have been removed from the illustration for clarity.

11. Assemble one M10 HEX JAM NUT (27) onto one end of the CABLE (28) approximately 1/2". Assemble the ROD END BEARING (29) to the same end of the CABLE until it meets the M10 HEX JAM NUT. Tighten the HEX JAM NUT securely.
12. Loosely assemble the ROD END BEARING (29) of the CABLE (28) to the WORKARM (16) using one M10 X 40mm BOLT (30), SPACER (31), 3/8" SAE WASHER (4) and M10 NYLOCK NUT (5) .
13. Route the cable over the CAM GUARD (25) and around the OUTPUT CAM ASSEMBLY (B). Insert the remaining end of the CABLE through the inner hole of the OUTPUT CAM ASSEMBLY.
Insert the CABLE RETAINING PLATE (32) over the end of the CABLE. Install two M8 HEX JAM NUTS (33) to the end of the CABLE.
Tighten the M8 HEX JAM NUTS until the WORKARM begins to move and all push pins still move in and out freely. Be sure the M8 HEX JAM NUTS are tight against each other.
14. Attach the OUTPUT CAM COVER PLATE (34) to the OUTPUT CAM ASSEMBLY (B) using three M10 X 45mm BOLTS (20) and three 3/8" SAE WASHERS (4).
15. Place the unit in the inteded place for use and check stability. If the unit is not stable, the FEET (D) can be adjusted by inserting or removing supplied SHIMS (36).

To add or remove SHIMS, loosen the LEVELING FOOT BOLT (E) and NUT (5) until the desired SHIM(S) can be inserted or removed. Lightly tighten the BOLT and NUT. Do not over-tighten the BOLT and NUT.

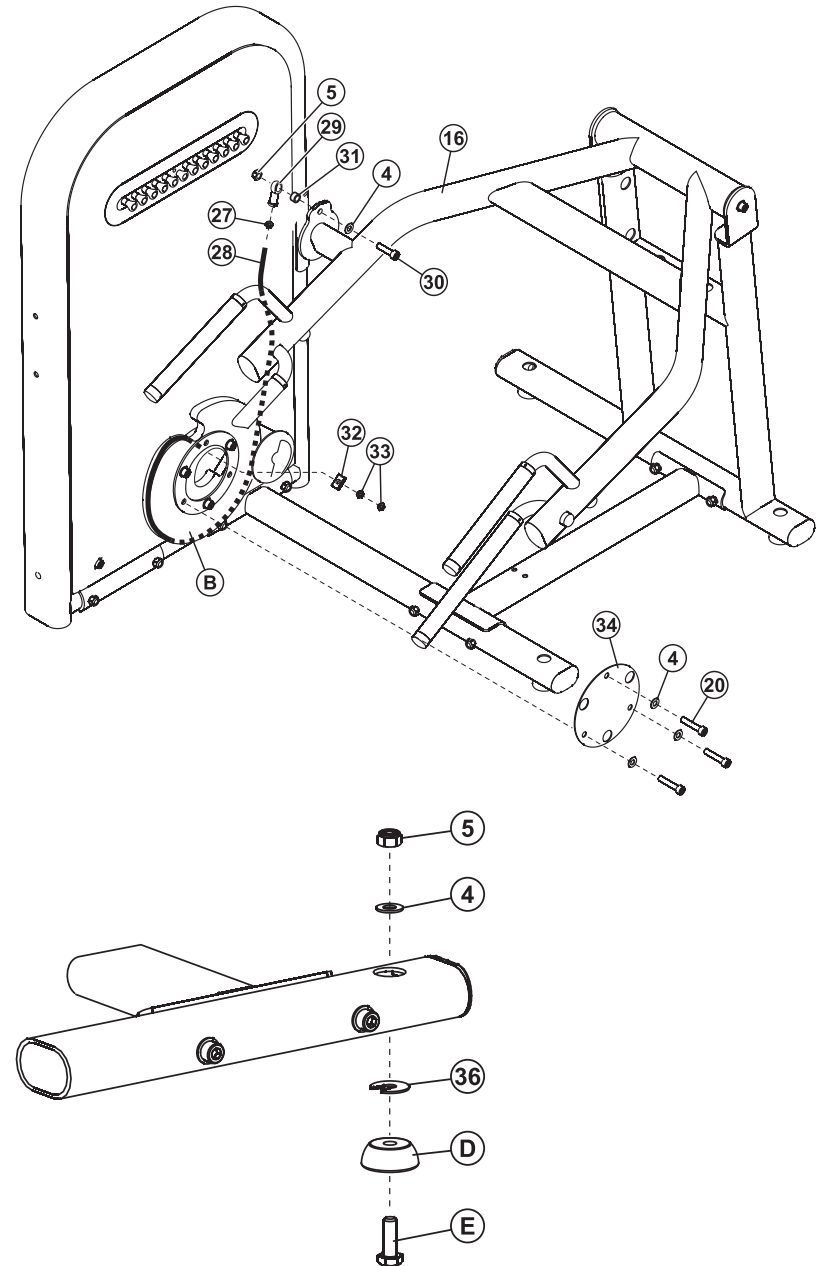

16. Attach the PLATFORM (35) to the PLATFORM FRAME (1) using four M10 X 25mm BOLTS (9) and four 3/8" SAE WASHERS (4) as shown. Tighten the BOLT securely.

17. Install HOLE PLUGS in all open bolt holes.

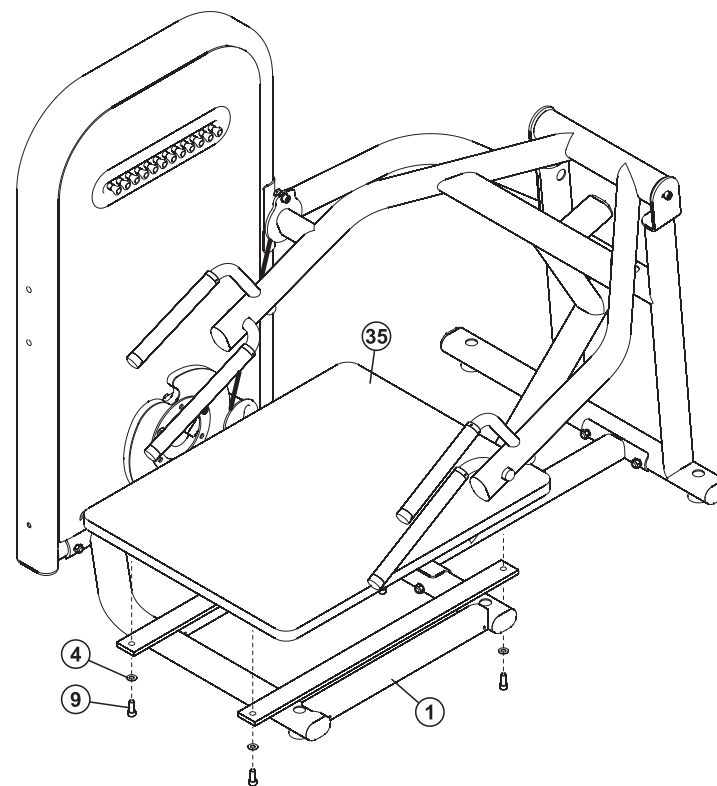

Squat
Assembly Instructions